

# Low-Cost Adaptive Solar Tracking System

Vidhi Prajapati\*, Bindiya Vaja\*, Jagdish M Rathod\*\*

\*Second Year Student, Electronics Engineering

\*\* Faculty of Electronics Engineering Department

BVM Engineering College-V V Nagar

Email: [vidhiprajapati869@gmail.com](mailto:vidhiprajapati869@gmail.com)

\*\*\*\*\*

## Abstract:

The Automatic Solar Tracker System improves solar panel efficiency by automatically tracking the sun's position using LDR sensors, a STMicroelectronics TDA2822 IC amplifier, and a DC geared motor. The system rotates the panel toward maximum sunlight, increasing energy generation compared to fixed solar panels. It is simple, low-cost, energy-efficient, and works without programming or microcontrollers, making it suitable for educational and small-scale renewable energy applications.

**Keywords — Mini solar panel, Resistor, LDR, 3.7V lithium cell, N20 Gear Motor, Cell holder, TDA2822IC, Mechanical Frame**

\*\*\*\*\*

## I. INTRODUCTION

With the rapid increase in global energy demand and environmental concerns, renewable energy sources have become essential for sustainable development. Among all renewable sources, solar energy is one of the most abundant, clean, and eco-friendly sources available. It can generate electricity without causing pollution or depleting natural resources. However, the efficiency of solar power systems mainly depends on the amount of sunlight received by the solar panels. In conventional systems, solar panels are fixed at a particular angle and position. Since the sun continuously changes its position throughout the day due to the Earth's rotation, fixed panels cannot always receive maximum sunlight, resulting in reduced efficiency and lower power generation.

To solve this problem, the Automatic Solar Tracker System is designed to automatically align the solar panel in the direction of maximum sunlight. The system uses Light Dependent Resistors (LDRs) to sense the intensity and direction of sunlight. When unequal light falls on the LDRs, a voltage difference is generated, which acts as the input signal for the control circuit. This signal is amplified using the

STMicroelectronics TDA2822 IC, a low-power amplifier IC capable of driving small loads. The amplified output controls a DC geared motor connected to the solar panel structure. The motor rotates the panel toward the side receiving higher light intensity until both LDRs receive equal illumination, ensuring that the panel remains perpendicular to the sun's rays for maximum energy absorption.

The system is simple, cost-effective, and energy-efficient because it requires only basic electronic components and operates on low voltage. It does not require programming or complex microcontrollers, making it highly suitable for educational projects and small-scale solar applications. The project demonstrates the practical application of analog electronics and control systems in renewable energy technology while improving solar energy utilization and reducing energy loss caused by improper panel orientation.

## II. PROBLEM STATEMENT

Solar panels in conventional systems are fixed at a single angle, so they cannot continuously face the sun as it moves throughout the day. This reduces the amount of sunlight received and lowers power generation efficiency. The main problem is the loss of solar energy due to improper panel alignment with the sun's position. To overcome this issue, the Automatic Solar Tracker System automatically adjusts the solar panel toward maximum sunlight using a tracking mechanism. This reduces energy loss, improves efficiency, eliminates manual adjustment, and provides a simple and cost-effective solution for better solar energy utilization.

## III. AIM AND OBJECTIVE

The aim of this project is to design and implement an Adaptive Solar Tracker System that continuously aligns a solar panel with the direction of maximum sunlight using light sensors and a control circuit, in order to maximize solar energy absorption and improve overall power generation efficiency.

### A. Objectives

- To design a system that can automatically detect the direction of sunlight using Light Dependent Resistors (LDRs).
- To develop a control mechanism using the TDA2822 IC to amplify sensor signals and drive the motor effectively.
- To implement a DC geared motor mechanism for rotating the solar panel toward the direction of maximum light intensity.
- To improve the efficiency of solar energy
- To create a simple, low-cost, and energy-efficient solar tracking system suitable for small-scale applications.

## IV. COMPONENTS USED

Component	Specification / Quantity
Mini Solar Panel	70 × 70 mm
LDR (Light Dependent Resistor)	2 units
Resistor	10 kΩ × 2
TDA2822 IC	Low-power Dual Amplifier
DC Geared Motor (N20)	Motor for panel rotation
Lithium Cell	3.7 V
Cell Holder	For battery mounting
Mechanical Frame	Mounting rotating structure

*Components Used in the System*

## V. BLOCK DIAGRAM

The block diagram in Fig. 1 illustrates the overall signal flow of the Adaptive Solar Tracker System. Sunlight falls on two LDR sensors placed on opposite sides of the solar panel. The differential resistance signal is fed into the TDA2822 IC acting as amplifier, whose output drives the DC geared motor. The motor rotates the solar panel until both LDRs receive equal illumination, maximizing the panel's power output.

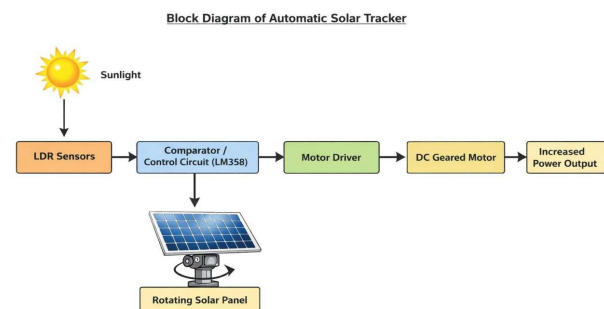

**Fig. 1 — Block Diagram of Automatic Solar Tracker**

## VI. CIRCUIT DIAGRAM

The connection diagram in Fig. 2 depicts the working circuit of the solar tracker. Two LDRs are connected in series with  $10\text{ k}\Omega$  resistors on each side to form voltage dividers. The midpoint voltages serve as the differential input to the TDA2822 IC. The amplified output drives the DC geared motor directly. Power is supplied by a 3.7 V Samsung lithium cell (INR18650-29E).

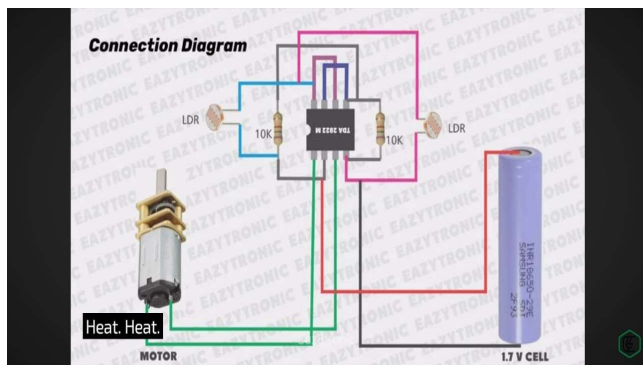

Fig. 2 — Connection Diagram of the Adaptive Solar Tracking System

## VII. WORKING

The Automatic Solar Tracker system operates by continuously detecting the direction of maximum sunlight and adjusting the position of the solar panel accordingly. The system mainly uses Light Dependent Resistors (LDRs) TDA2822 IC, and a DC geared motor to achieve automatic tracking. Two LDR sensors are placed on opposite sides of the solar panel. These sensors are responsible for sensing the intensity of sunlight. When both LDR receive equal light, their resistance values remain similar, and the system stays in a balanced condition. In this state, no significant voltage difference is generated, and the motor remains stationary. As the position of the sun changes throughout the day, one LDR receives more light than the other. This creates a difference in resistance, which leads to a voltage difference between the two sensors. This small electrical signal is then given as input to the TDA2822 IC, which acts as an amplifier in the circuit. The TDA2822 IC amplifies the weak signal from the LDRs and produces an output strong enough to drive the DC geared motor. Based on the direction of the light intensity difference, the motor rotates the solar panel

toward the side receiving higher sunlight. The panel continues to rotate until both LDRs again receive equal light intensity. At this point, the system returns to a balanced state, and the motor stops. This process repeats continuously as the sun moves across the sky, ensuring that the solar panel always remains aligned with the sun. Thus, by automatic all y adjusting the orientation of the panel, the system maximizes solar energy absorption and improves the overall efficiency of power generation compared to a fixed solar panel system.

## VIII. ADVANTAGES

- Increases solar energy efficiency by continuously tracking sunlight.
- Operates automatically without manual adjustment.
- Improves utilization of available solar energy and reduces energy loss.
- Consumes low power using simple components like LDRs and the STMicroelectronics TDA2822 IC.
- Simple, low-cost, and easy-to-implement design.
- Provides better and more consistent power generation.
- Requires low maintenance due to fewer complex components.
- Useful for educational and renewable energy learning applications.
- Increases the lifespan of the solar panel system through efficient operation.
- Can be used in remote areas where maximum solar energy utilization is needed.

## IX. DISADVANTAGES

- Higher cost than fixed solar panels due to extra components like sensors and motors.
- Mechanical parts increase system complexity and wear over time.
- Requires regular maintenance for smooth operation.
- DC motor consumes some power during panel movement.

- Tracking accuracy may reduce during cloudy weather or low sunlight conditions.
- Basic designs may have limited tracking accuracy.
- System installation and alignment can be time-consuming.
- Mechanical failure of motors or joints can affect overall system performance.

## **X. FUTURE SCOPE**

- Implementation of dual-axis tracking for more accurate sun alignment.
- Use of microcontrollers like Arduino for better control and accuracy.
- Integration with battery storage systems for energy storage and backup.
- Use of advanced sensors for improved tracking performance.
- Upgradation with better motor control mechanisms for smooth movement.
- Expansion for large-scale solar panel installations and solar farms.
- Addition of IoT-based remote monitoring and control systems.
- Integration with smart energy and smart grid systems.
- Further improvement in energy efficiency and power generation.
- Better utilization of solar energy with fully automatic operation.

## **XI. CONCLUSIONS**

The Automatic Solar Tracker System was successfully developed using LDR sensors, a STMicroelectronics TDA2822 IC, and a DC geared motor to automatically align the solar panel toward maximum sunlight. The system improves solar energy absorption and power generation compared to fixed solar panels by continuously tracking the sun's movement throughout the day. It is simple, cost-effective, energy-efficient, and suitable for educational as well as small-scale renewable energy applications. The project demonstrates the practical application of analog electronics, sensors, and

control systems in renewable energy technology while reducing energy loss caused by improper panel alignment. It also helps in understanding real-time applications of electronic components and encourages the use of sustainable energy solutions for environmental protection. Furthermore, the system can be upgraded in the future using microcontrollers, advanced sensors, and IoT technology for improved accuracy, performance, and large-scale applications.

## **XII. ACKNOWLEDGMENT**

I would like to express my sincere gratitude to all those who supported and guided me throughout the successful completion of this mini project on Automatic Solar Tracker. I am especially thankful to Prof. (Dr.) J. M. Rathod for his valuable guidance, encouragement, and continuous support during the project work. I also thank the faculty members of Birla Vishvakarma Mahavidyalaya for providing the necessary facilities and academic support. Special thanks to my teammate for her cooperation, teamwork, and dedication in completing this project successfully. I am also grateful to my institution, online resources, family, and friends for their constant motivation, encouragement, and support throughout the project.

## **REFERENCES**

- [1] Electronic Devices and Circuit Theory–Robert L. Boylestad & Louis Nashelsky, for understanding basic electronic components and circuit concepts.
- [2] Proteus Design Suite–Used for circuit simulation, testing, and validation of the solar tracker design.
- [3] SnapEDA–Used for downloading electronic component libraries and footprints.
- [4] YouTube Tutorials–For learning the working and implementation of automatic solar tracking systems.

- [5] ChatGPT–Used for assistance in project documentation, content improvement, and conceptual understanding.
- [6] Datasheets of components such as LDR, TDA2822 IC and DC Motor–For technical specifications and operational details. (2002)