

## Offline Voice Recognition Module for ON/OFF Appliances

Aditya Sharad Shinde<sup>1</sup>, Sudeep Subhash Tawlarkar<sup>2</sup>, Yuvraj Dattatray Patil<sup>3</sup>, Akashay Sharad Bansi<sup>4</sup>

<sup>1234</sup>Student, Department of Electrical Engineering, MET's Institute of Technology – Polytechnic, Adgaon, Nashik, Maharashtra, India

Project Guide : Prof. C.P. Patil

\*\*\*\*\*

### Abstract:

*Home automation is becoming an user-friendly Voice Controlled Home Automation System using an Arduino Nano microcontroller and an offline essential part of modern living as it improves comfort, energy efficiency, and accessibility. This project presents a cost-effective and such as a fan and light through voice recognition module. The system allows users to control electrical appliances predefined voice commands without requiring an internet connection.*

*The core of the system is an AI Thinker-based offline voice command recognition module that detects specific spoken phrases and sends corresponding serial integer data to the Arduino. The Arduino processes these commands and controls a two-channel relay module to switch AC and DC loads such as lamps and motors. A 5V SMPS power supply provides regulated power to all components. Indicator LEDs are used to show system power and command detection status, making the system intuitive and interactive.*

*Unlike cloud-based smart home solutions, this system works fully offline, ensuring privacy, reliability, and faster response time. The project demonstrates how embedded systems can be used to develop low-cost automation solutions suitable for homes, hostels, and small offices. It is particularly beneficial for elderly and physically challenged individuals who may find manual switching inconvenient*

**Keywords** — Automation, Voice command, Arduino, Smart Home

\*\*\*\*\*

### I. INTRODUCTION

rapid advancement in embedded systems and artificial intelligence has led to significant growth in smart home technologies. Home automation systems allow users to control electrical devices conveniently, enhancing safety, energy efficiency, and quality of life. Traditional home automation systems often rely on mobile applications or internet connectivity, which increases complexity and cost. This project aims to design a simple, offline voice-controlled automation system using affordable components and minimal infrastructure

Voice control has emerged as one of the most natural forms of human-machine interaction. It eliminates the need for physical switches and enables hands-free operation. This is particularly useful for elderly individuals, differently-abled people, and situations where manual interaction is inconvenient. By integrating voice recognition with microcontroller technology, it is possible to create efficient automation systems that are reliable and easy to operate.

The proposed system uses an Arduino Nano as the central controller due to its compact size, low power consumption, and ease of programming. An offline AI Thinker voice recognition module is used to detect predefined commands. Unlike cloud-

based assistants, this module works without internet access, ensuring faster response and better data privacy. When a command is recognized, the module sends a numeric signal to the Arduino, which then controls electrical loads via a relay module

## II. LITERATURE REVIEW

The research on IoT-based smart home systems highlights significant advancements in automation, control, and energy management. One study focuses on the development of an IoT-based smart home automation system that allows users to remotely control household appliances through a mobile application. This system utilizes a microcontroller-based relay mechanism along with various sensors to enable both automation and security features. Communication is established over Wi-Fi using the ESP8266 module, and the MQTT protocol is employed for efficient cloud-based data transmission. However, a key limitation of this system is its strong dependence on internet connectivity, which makes it non-functional during network failures.

Another study presents an IoT-based smart home energy management system designed to monitor and optimize power consumption. This system incorporates smart meters and IoT sensors to collect energy usage data, which is then analyzed using cloud-based data analytics to identify consumption patterns and reduce energy wastage. Users can also access and control their energy data remotely through a mobile application. Despite its advantages, the system has a drawback in that it relies heavily on cloud services, potentially leading to increased operational costs.

Overall, these studies demonstrate how IoT technologies enhance convenience, efficiency, and energy optimization in smart homes, while also highlighting challenges such as internet dependency and cost factors.

## III. METHODOLOGY

The methodology of the proposed system begins with the selection of appropriate hardware components followed by the overall system design. A voice recognition module is then trained using predefined voice commands to ensure accurate input detection. This module is interfaced with the Arduino through serial communication, enabling the transfer of command data. The Arduino is programmed to decode the received command IDs and execute the corresponding actions. A relay module is integrated to control home appliances based on these commands, while LED indicators are implemented to display the system status. The system is then tested using various voice commands to evaluate its performance and accuracy. Any errors identified during testing are addressed through debugging and performance optimization. Finally, the complete system is assembled, and proper documentation is prepared to summarize the design and implementation process.

## IV. HARDWARE DESCRIPTION

When the system is powered ON, the 5V SMPS supplies regulated voltage to all modules. The power indicator LED glows continuously, indicating that the system is active and ready to receive commands. The Arduino initializes serial communication and sets relay pins as output.

The AI Thinker voice recognition module continuously listens for predefined wake phrases such as "Hey pudding" or "Hello pudding." Once the wake command is detected, the module responds with a stored audio acknowledgment and becomes ready to process control commands.

When the user speaks a command such as "Start the fan," the voice module processes the audio pattern and matches it with stored templates. If recognized successfully, it sends a specific integer code to the Arduino via serial communication. The Arduino reads this value and executes the corresponding control logic.

**V. RESULTS AND DISCUSSION**

Testing was conducted to verify the functionality, reliability, accuracy, and safety of the Voice Controlled Home Automation System. The main objective was to ensure that the system correctly recognizes predefined voice commands and performs the corresponding actions without delay or malfunction. Multiple testing scenarios were created to evaluate real-time performance, including different users, environmental conditions, and repeated command execution.

The testing process was divided into hardware testing, software testing, functional testing, and performance evaluation. Each module was tested individually before conducting complete system testing to ensure proper

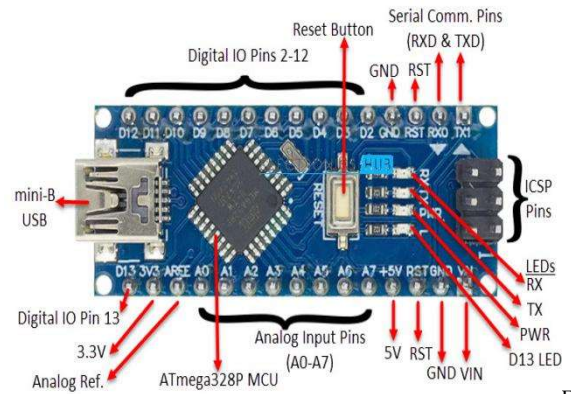

Fig .arduino nano board

The NodeMCU acts as the main controller for processing data and enabling Wi-Fi communication with the mobile application.

**VI. HARDWARE FIGURES**

**A. Circuit Diagram**

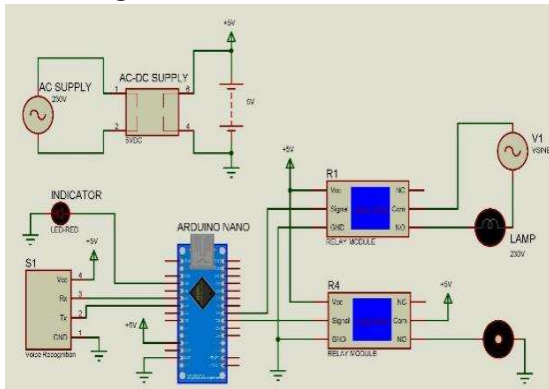

Fig. 1 Circuit Diagram

The system consists of a solar panel connected to a solar charge controller that charges a 3.7 V Li-ion battery and powers the NodeMCU ESP8266 controller. An RFID module is used for user authentication, and upon successful verification, a relay activates the wireless power transfer unit, which transfers energy from the transmitting coil to the receiving coil to charge the EV battery safely and wirelessly.

**B. Arduino nano board**

**C. Relay Module**



Fig. 3 5V Relay Module

The relay module is used to control high-voltage and high-current appliances using low-voltage microcontroller signals. In this project, it switches an AC lamp and a DC motor (fan). The relay provides electrical isolation between the Arduino and high-power loads, ensuring safety and reliable switching.

**D. Voice Recognition module**

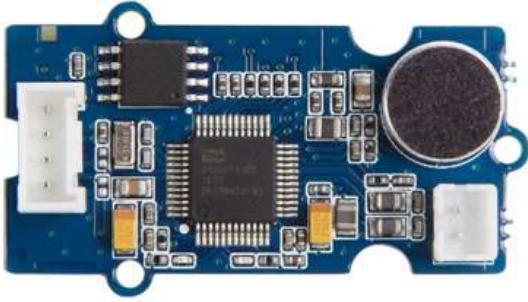

Fig. Voice Recognition module

Relay is one kind of electro-mechanical component that functions as a switch. The relay coil is energized by DC so that contact switches can be opened or closed. A single channel 5V relay module generally includes a coil, and two contacts like normally open (NO) and normally closed (NC). This article discusses an overview of the 5V relay module & its working but before going to discuss what is relay module.

## VII. CONCLUSION

The Voice Controlled Home Automation System using Arduino demonstrates a practical and affordable approach to implementing smart home technology. By combining an offline voice recognition module with a microcontroller-based control system, the project successfully eliminates the need for internet connectivity while maintaining reliability and responsiveness. The system effectively converts spoken commands into electrical actions, enabling convenient control of household appliances.

## VIII. FUTURE SCOPE

Although the proposed system demonstrates effective functionality in controlling home appliances through voice commands, there is significant scope for further enhancement to make it more efficient, flexible, and user-friendly. One major improvement can be the integration of a mobile application-based control system, which would allow users to operate appliances not only through voice commands but also through a graphical interface, providing greater convenience and accessibility. This dual-mode control (voice + app) would be especially useful in situations where voice recognition may not perform accurately due to noise or pronunciation variations.

Additionally, the system can be expanded by incorporating advanced IoT capabilities such as cloud connectivity, enabling users to monitor and control their home devices remotely from anywhere in the world.

Further improvements can include the integration of artificial intelligence and machine learning algorithms to make the system smarter by learning user behavior and automating tasks accordingly, such as turning lights or fans on/off based on user habits. The addition of more advanced sensors can enhance security features, including motion detection, fire detection, and gas leakage alerts, making the system more reliable and safe. Energy management features can also be integrated to monitor power consumption and suggest ways to reduce electricity usage, thereby making the system more energy-efficient and cost-effective.

Moreover, the system can be upgraded to support multiple languages in voice recognition to make it more accessible to a wider range of users. Compatibility with popular virtual assistants can also be considered to improve usability. Future developments may also focus on improving system reliability by reducing dependency on a single mode of communication and ensuring functionality even during network failures. Overall, by incorporating these enhancements, the system can evolve into a more intelligent, secure, scalable, and user-centric smart home solution.

## IX. REFERENCES

- [1] S. Kumar, P. Gupta, and R. K. Sharma, "IoT-Based Smart Home Automation System," *International Journal of Advanced Research in Computer Science*, vol. 10, no. 3, pp. 45-52, 2021M
- [2] R. Patel, T. Singh, and A. Verma, "Smart Home Energy Management Using IoT," *IEEE Transactions on Smart Grid*, vol. 12, no. 5, pp. 2876-2884, 2022.
- [3] L. Zhou, J. Wang, and Y. Chen, "Design and Implementation of a Smart Home System with Gas Leakage Detection,"]
- H. Alzahrani and M. S. Alam, "Wireless Smart Home Automation System Based on ESP8266," *IEEE Internet of Things Journal*, vol. 9, no. 1, pp. 220-227, 2022
- P. K. Mishra, A. Dubey, and R. Agarwal, "Secure IoT-Based Home Automation System with Local and

Cloud Control," IEEE Access, vol. 11, pp. 4512-4525, 2023

6. Y. Kim, J. Park, and K. Lee, "AI-Integrated Smart Home Automation System," Journal of Artificial Intelligence and IoT Applications, vol. 7, no. 3, pp. 115-130, 2023]
7. A. Sharma and B. Roy, "A Review on IoT-Based Smart Homes: Security Challenges and Solutions," IEEE Transactions on Consumer Electronics, vol. 68, no. 4, pp. 3412-3425, 2022.