

## An Automatic Phase Changer Using Arduino

<sup>1</sup>Mr. Bhanudas D. Tale, <sup>2</sup>Dhanashri M. Pilare, <sup>3</sup>Pushkar S. Karambe, <sup>4</sup>Vishakha R. Bisane, <sup>5</sup>Anurag A. Patil, <sup>6</sup>Asmita V. Jamne

<sup>1</sup>Associative Professor and Head, Department of Electrical Engineering, Kavikulguru Institute of Technology & Science, Ramtek, Nagpur, Maharashtra, India - 441106

<sup>2</sup>B.Tech. Scholar, Department of Electrical Engineering, Kavikulguru Institute of Technology & Science, Ramtek, Nagpur, Maharashtra, India - 441106

<sup>3</sup>B.Tech. Scholar, Department of Electrical Engineering, Kavikulguru Institute of Technology & Science, Ramtek, Nagpur, Maharashtra, India - 441106

<sup>4</sup>B.Tech. Scholar, Department of Electrical Engineering, Kavikulguru Institute of Technology & Science, Ramtek, Nagpur, Maharashtra, India - 441106

<sup>5</sup>B.Tech. Scholar, Department of Electrical Engineering, Kavikulguru Institute of Technology & Science, Ramtek, Nagpur, Maharashtra, India - 441106

<sup>6</sup>B.Tech. Scholar, Department of Electrical Engineering, Kavikulguru Institute of Technology & Science, Ramtek, Nagpur, Maharashtra, India - 441106

---

### Abstract:

The present electrical systems require continuous power supply to support all domestic and business operations and industrial work. The three-phase system experiences total power loss when any of its three phases fails because this interrupts power supply to all connected electrical loads. This presents an Arduino-based Automatic Phase Changer (APC) system which continuously checks all three phases for power availability and voltage status to automatically switch between phases when one experiences power loss. The system uses voltage-sensing circuits together with relays and a microcontroller to enable automated switching which operates without requiring any manual control. The Arduino-based design achieves better operational flexibility because it enables accurate system performance assessment while allowing future development of IoT monitoring and fault detection capabilities. The system provides an effective solution at a low price point which businesses and hospitals and home users can use in their essential operations.

**Keywords** — Automatic Phase Changer, Arduino, Three-Phase System, LCD Display System, Load Switching.

---

### I. INTRODUCTION

Electrical power serves as the essential foundation for contemporary existence because all electrical devices need constant power to function correctly. The widespread adoption of three-phase power systems occurs because these systems deliver superior efficiency and superior capacity to handle electrical loads and enhanced system dependability. Distribution systems experience common phase failures which arise from automatic protection equipment operation during fault

conditions and from fuse link replacements and from equipment running beyond its rated capacity and from necessary maintenance procedures.

The operational process begins with manual changeover switches which move the electrical load from the damaged phase to the operational phase. The process consumes excessive time because it requires workers to complete the task. Automatic phase changers exist as a solution which resolves this operational restriction.

The research presents a system which functions as an automatic phase changer based on the

Arduino platform. The system detects which phases are available and automatically transfers the electrical load between phases according to the established priority order of R to Y to B for maintaining continuous power supply.

## II. LITERATURE REVIEW

The literature review provides complete information about automatic phase changer systems which help maintain continuous power supply to three-phase electrical systems. [1]Seahi Publication (IJSETR, 2024) conducts research on automatic phase selector systems which monitor three phases continuously and transfer load to operational phases during phase failures. The system employs sensing circuits together with relays and control logic to perform voltage status checks, which allow it to switch operations quickly without needing intermission times or human intervention that customary changeover systems require.

The research presented in [2]IJLTEMAS (2020) introduces an automatic phase changer with optimal selection which enhances the previous concept. The system selects its voltage- and load-based most stable phase through its phase selection process, which prevents selection of all other non-dominant phases. The system delivers voltage stabilisation which benefits connected equipment performance while safeguarding sensitive devices from damage. The system uses its sensing circuits and relays together with control logic to check voltage status, which enables instant operation changes without the need for downtime or human staff that standard systems need during transitions.

The study by [11]IJPREMS (2023) focuses on the practical implementation of an automatic phase selector using available phase supply. It emphasizes the importance of proper component selection and circuit design, including the use of transformers for voltage reduction, diodes for rectification, voltage

sensors for monitoring, relays for switching, and a control unit for decision-making. The study demonstrates that a well-designed system can ensure reliable, fast, and seamless operation during phase failures, making it suitable for domestic, industrial, and commercial applications.

The review paper by [4]IJERT (2017) provides a comprehensive analysis of the circuit design and working methodology of automatic phase changers. The system uses relays and voltage sensors together with control circuits to perform continuous phase monitoring while it automatically moves the load to different phases whenever a fault occurs. The research team found critical design shortcomings that existed in older systems because they did not have enough load capacity and they lacked real-time monitoring and intelligent decision-making capabilities.

## III. PROPOSED SYSTEM

The proposed system presents an Arduino Nano-based automatic 3-phase changer designed to ensure an uninterrupted power supply when one phase fails. The system detects the operational state of the three RYB phases and its relay system transfers electrical load to the functional phase. The project aims to enable continuous power delivery to the connected load without any need for manual operation of the power system.

The system consists of four major sections:

1. Phase sensing unit
2. Control unit (Arduino Nano)
3. Switching units (relay modules)
4. Display unit (LCD)

The system operates through its four distinct sections which perform their specific tasks to maintain system functionality.

#### IV. METHODOLOGY

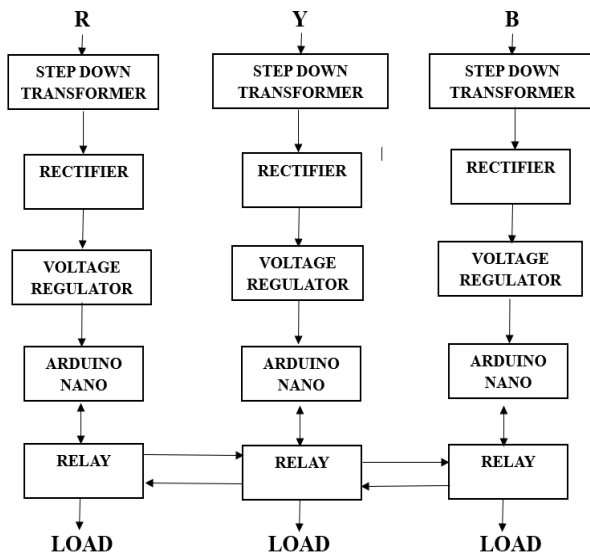

Fig. 1 Block Diagram

##### A. Working

The block diagram illustrates an automatic phase changer which uses Arduino technology to maintain continuous power delivery to a load by selecting the most suitable phase from the available three-phase power system (R, Y, and B). The system implements identical phase processing paths to achieve proper control and monitoring operations.

The system starts its operation by delivering the three input phases—R (Red), Y (Yellow), and B (Blue)—to three different step-down transformers. The transformers reduce the high mains voltage (typically 230V AC per phase) to a much lower and safer level (such as 12V AC). Sensitive electronic components require this step because they cannot function at high voltage levels which exceed their operational threshold. The transformers produce reduced AC voltage which flows through a rectifier that transforms the AC signal into a pulsating DC output. The control

circuits need stable DC for operation, so the voltage regulator processes the output to deliver constant stable DC between 5V and 12V. The system uses this regulated voltage to supply power to both the Arduino Nano and its relay circuits.

The Arduino Nano functions as the system's primary central control unit. The system continuously checks all three phases' voltage status through its processed direct current signals. The system uses its programmed logic to determine which phase is currently working and functioning normally. The Arduino is typically programmed with a priority sequence—for example, giving preference to the R phase first, then Y, and then B. The Arduino selects the preferred phase to supply power to the load when it detects that the phase exists. The Arduino detects the voltage loss on that phase when an electrical failure occurs, and it automatically switches to control by using the next active phase.

The relays function as the switching mechanism which handles switching operations by using electrically operated switches that the Arduino controls. Each relay operates to control one specific phase. The Arduino control system uses a relay signal to create a load connection to the circuit which closes for the selected phase. The relays in the diagram are interconnected, allowing smooth and automatic transition from one phase to another without manual intervention. The control logic has been designed to enable operation of only one relay at any moment, which helps to prevent short circuits between different phases.

The relay system output connects to electrical equipment which includes lights, fans, motors, and other devices that the load powers. The system provides continuous power supply to the load from the currently active phase selection. The system automatically transfers the load to another

available phase when one or two phases stop working.

The system enhances operational reliability by minimising system downtime because it removes manual phase switching operations from the process. The solution proves effective for domestic and industrial applications because it addresses areas that experience frequent phase failures.

**B. Advantages**

1. Automatic operation (no manual switching required)
2. Continuous power supply
3. Simple and low-cost design
4. The system operates in both residential and industrial environments.

**C. Application**

1. The system serves homes and residential buildings.
2. The system serves hospitals and critical systems.
3. The system serves commercial shops and buildings.

**D. Limitation**

1. The system operates only at low-load capacity according to the relay specifications.
2. The system requires safety measures which need proper isolation.
3. The system experiences a tiny but existent delay during the switching process.

**V. RESULT**

We successfully built and tested an automatic 3-phase changer that uses an Arduino Nano system. The system detected phase availability with complete accuracy and switched the load to a healthy phase during phase failure. The switching system maintained an uninterrupted power supply

through its quick and dependable operation which created minimal service interruptions.

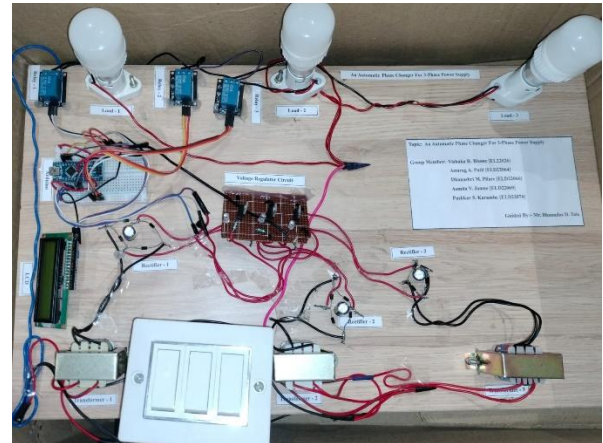

Fig. 2 Hardware Setup of Automatic Phase Changer

R Phase	Y Phase	B Phase	Output Voltage
Off	Off	Off	No Supply
On	Off	Off	Phase R
Off	On	Off	Phase Y
Off	Off	On	Phase B
Off	On	On	Phase Y or Phase B
On	On	On	All Phases

Fig. 3 Result of Automatic Phase Changer

**VI. CONCLUSION**

The automatic 3-phase changer using Arduino Nano provides an efficient solution which maintains power supply through its reliable automatic system. The system identifies available phases for power transfer which enables load switching to the detected phase, thus eliminating manual operation and stopping power outages. The design is simple yet affordable, which makes it

suitable for multiple applications that require a continuous power supply.

### **Future Scope**

1. The system will enable remote monitoring through IoT integration.
2. The system will use solid-state relays to achieve better switching performance.

### **ACKNOWLEDGMENT**

We would like to express our sincere gratitude to our project guide for their valuable guidance, support, and encouragement throughout the completion of this project. We are also thankful to the faculty members of our department for providing the necessary resources and knowledge.

We are grateful to everyone who contributed directly or indirectly to the successful completion of this project.

### **REFERENCES**

- [1] I. Usman, "Design and construction of an automatic phase selector for 3-phase power supply," *International Journal of Innovative Scientific*

- & *Engineering Technologies Research*, vol. 12, no. 3, pp. 64–70, Jul.–Sept. 2024.
- [2] S. ABUTU, "Automatic Phase Changer with Optimal Selection," *International Journal of Latest Technology in Engineering, Management & Applied Science (IJLTEMAS)*, vol. IX, Issue V, May 2020.
- [3] R. Patil, P. Rajput, D. Marathe, and Y. Mahajan, "3-Phase Switching System with Relay Mechanism," *International Research Journal of Engineering and Technology (IRJET)*, vol. 11, no. 11, pp. 559–562, Nov. 2024.
- [4] V. Tippa, A. Kedar and K. Nikum, "Automatic phase changer: A review," *Int. J. of Engineering Research & Technology (IJERT)*, ICIATE-2017 Conference Proceedings, vol. 5, no. 1, Special Issue, 2017.
- [5] P. G. Wankhade, M. P. Dongre, A. G. Vigne, S. S. Chaudhari, M. R. Chinche, K. Quazi, and S. Jalit, "Automatic phase selector with regulating power supply," *Int. J. of Research and Analytical Reviews (IJRAR)*, vol. 9, no. 2, pp. 369-372, May 2022.
- [6] C.L. WADHWA - "ELECTRICAL POWER SYSTEMS" (6<sup>th</sup> edition, New Age International Publishers)
- [7] D. P. KOTHARI, I J NAGRATH -"POWER SYSTEM ENGINEERING "(2<sup>nd</sup> edition), 2007
- [8] GIORGIO RIZZONI – "ELECTRICAL ENGINEERING" (7<sup>th</sup> edition, McGraw INC.), 2004
- [9] M. A. Mazidi, J. G. Mazidi, and R. D. McKinlay, "The 8051 Microcontroller and Embedded Systems," Pearson Education, 2006.
- [10] Simon Monk, *Programming Arduino: Getting Started with Sketches*, McGraw-Hill Education, 2016.
- [11] R. Patel and S. Desai, "Automatic Phase Selector Implementation Using Amongst Available Phase Supply," *International Journal of Progressive Research in Engineering Management and Science (IJPREMS)*, vol. III, no. V, pp. XX–XX, May 2023.