

# Dynamic Voltage Restorer (DVR) for Power Quality Improvement in Power System: A Review

Tananjay Prakash<sup>1</sup>, Prof. Durgesh Vishwakarma<sup>2</sup>

<sup>1</sup>(M.tech Scholar, Radharaman Engineering College Bhopal  
Email:gangaputraprakash@gmail.com)

<sup>2</sup>(Assistant Professor, Electrical Department, Radharaman Engineering College, Bhopal  
Email:durgeshrecek@gmail.com)

\*\*\*\*\*

## Abstract:

Power Quality is an essential concern in the modern power system that can affect consumers and utility. The integration of renewable energy sources, smart grid systems and extensive use of power electronics equipment caused innumerable problems in the modern electric power system. Current and voltage harmonics, voltage sag, and swell can damage the sensitive equipment. one of the methods by which power quality problems might be addressed is to apply power electronic devices in the form of custom power devices. One of such devices is Dynamic Voltage Restorer (DVR) which is connected in series to distribution networks Dynamic Voltage Restorer (DVR) is a potential Distribution Flexible AC Transmission System (D-FACTS) device widely adopted to surmount the problems of non-standard voltage, current, or frequency in the distribution grid. It injects voltages in the distribution line to maintain the voltage profile and assures constant load voltage. This paper reviews on the application of DVR for Voltage Compensation

Keywords — **Dynamic voltage restorer, Power Quality, sag, swell, harmonics.**

\*\*\*\*\*

## I. INTRODUCTION

Appropriation segment is viewed as the significant connection between power industry and shoppers; for this, it habitually is assessed and evaluated by individuals. Subsequently, crucial for manage power quality on dissemination segment is fundamental. Then again, dissemination networks are presented to customary unsettling influences for sinusoid waveforms, for example, dynamic voltage hang and voltage swell, sounds and capacitive exchanging thus harm power quality and organization dependability to huge degree. Such previous unsettling influences are brought about by certain shoppers and influence different customers and organization hardware. Moreover, given a few mishaps organization could force unsettling

influences on vulnerable shoppers. Consequently, appropriation organizations are answerable for offering solid and excellent power for their purchasers. This requires use of force quality regulator gadgets in the organizations. This may be finished utilizing power electronic gadgets called custom power gadgets, further developing aggravations. An illustration of such gadgets is viewed as DVR.

The power framework is partitioned into the accompanying parts as age, transmission, dispersion, and by utilizing other transmission line power frameworks is taken care of to various burdens on the conveyance side. Power quality assumes an imperative part in the power framework when variable power is provided to the heap. In this

manner, the homegrown and modern clients with sensitive burdens are impacted by the low quality of force. Indeed, even there is different sort of burden on the dispersion side, yet unfortunate power quality influences the delicate loads more than others.

There are numerous applications where the delicate burden has a rising interest, as in clinic's activity theaters, semiconductor frameworks in handling plants, information base frameworks, instruments to control air contamination in packed regions, exact and precise hardware are expected by information handling, and specialist co-ops. Assuming the influence framework causes the plunges and contorted voltages, these gadgets might fall flat, and such a gadget's disappointment prompts wastage of a significant measure of cash. Hence, the conveyance side is reliant upon power quality. Electrical qualities are set by the power framework that doesn't upset the framework's exhibition and fill its role in a controlled way. In this article, voltage enlarge and misshaped voltage with high sounds in it are examined.

Whenever the heap voltage being upset, it causes voltage droop, transient, swell, and high mutilated voltage with music and Total Harmonic Distortion (THD) because of the event of the shortcomings. The penetrability of voltage lists and music issues is generally to the fragile instruments.

Not many issues happen in the consequence of voltage droop that may likewise cause unsettling influence of forces in the engines, gadget consuming, misring in the gadget, and so on. The consonant is a fundamental issue for power quality to be tackled really.

## **II. POWER QUALITY**

The utilities, as well as industrial and commercial electrical consumers, are paying more attention to power quality. A bus voltage that closely matches a sinusoidal waveform of the required magnitude is regarded as having good power quality. Higher power quality is required by users in order to use more sensitive loads, automate processes, and

increase quality. Constant (rms) value, constant frequency, symmetrical three-phases, pure sinusoidal wave form, and low THD are some basic criteria for power quality. If the power quality level is deemed to be high, certain parameter values should be kept within specified standards-defined ranges.

### **➤ Power Quality Problems**

**PQ problems can be summarized as follows**

#### **1. Voltage sag (or dip)**

A decrease of the normal voltage level between 10 and 90% of the nominal (rms) voltage at the power frequency, for durations of 0.5 cycle to 1 minute.

#### **2. Very short interruptions**

Total interruption of electrical supply for duration from few milliseconds to one or two seconds.

#### **3. Long interruptions**

Total interruption of electrical supply for duration greater than 1 or 2 seconds

#### **4. Voltage spike**

Very fast variation of the voltage value for durations from several microseconds to few milliseconds. These variations may reach thousands of volts, even in low voltage.

#### **5. Voltage swell**

It is defined as an increase in rms voltage or current at the power frequency for durations from 0.5 cycles to 1 minute. Typical magnitudes are between 1.1 and 1.8 pu.

#### **6. Harmonic distortion**

Voltage or current waveforms with non-sinusoidal shape. It is assumed to be the waveform corresponds to the sum of different sinewaves with different magnitude and phase, having frequencies that are multiples of power-system frequency.

#### **7. Voltage fluctuation**

Oscillation of voltage value, amplitude modulated by a signal with frequency of 0 to 30 Hz.

### 8. Noise

Superimposing of high frequency signals on the waveform of the power-system frequency.

### 9. Voltage unbalance

A voltage variation in a three-phase system in which the three voltage magnitudes or the phase angle differences between them are not equal.

## III. DYNAMIC VOLTAGE RESTORER (DVR)

To reduce voltage sags and increase power quality, a wide-area solution is necessary. The Dynamic Voltage Restorer (DVR) is a novel method (voltage source converters connected in series between the supply system and the sensitive load). The DVR is a new device that protects sensitive loads from voltage sags and other voltage disturbances while also reducing harmonic distortion. The DVR was created with big loads in mind, ranging from a few MVA to 50 MVA or greater.

The DVR is a collection of bespoke power devices that are linked together. Because of the advantages of series compensation over shunt compensation (such as DSTATCOM) in terms of necessary power rating for typical voltage stiffness, it has been used as a decisive solution.

The DVR offers a quick, adaptable, and cost-effective solution to voltage sag issues. It can restore the load voltage in a matter of milliseconds, avoiding any power interruptions to that load.

A Voltage Source Inverter (VSI), an inverter output filter, an energy storage device coupled to the DC connection, a control system, a protection system, and an injection transformer make up the DVR.

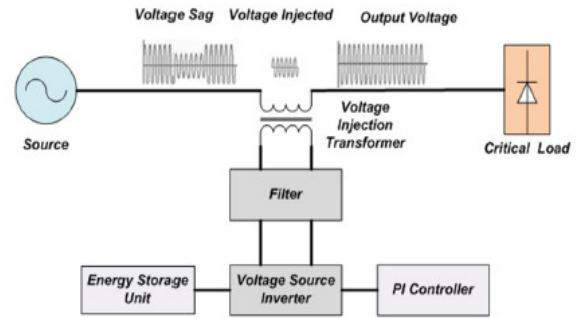

Fig. 3: Basic Proposed DVR

## IV. OPERATING PRINCIPLE OF UPFC

### A. Energy Storage Unit

Low and high voltage levels are corrected and DVR efficiency is increased using this commonly used DVR topology unit. Energy storage units are typically batteries, superconducting magnetic energy storages, and super capacitor energy storages.

### B. Voltage Source Inverter

This is the most important part of the DVR topology. It enables the appropriate voltage to be supplied to the load for compensation. The VSI is made up of power electronic components that can convert direct current (DC) into sinusoidal current (AC) with the necessary amplitude, frequency, and phase angle from the energy storage unit. VSI is powered by a DC voltage supply with a low input impedance, and the output voltage is unaffected by load current.

### C. Filter

Because of its semiconductor components, DVR is a non-linear device. The output voltage waveforms would be distorted as a result of this. A filter is used to get distortion-free electricity to the load to avoid the problem of distorted wave patterns.

### D. Voltage Injection Device

In DVR topology, a voltage injection device, such as a power transformer, is used and coupled to

each phase separately. Its primary function is to provide the required voltage to the load. The choice of MVA rating, impedance, and turns ratio determines the voltage injection transformer's performance and reliability.

#### **E. By-pass Switch**

Large current flows following a fault on the power supply will result in excessive current flows through the DVR, hence another path for the current must be provided. The by-pass switch can be used to do this.

#### **F. Controlling Device**

In any system, the controller plays a critical role. The controller contributes to the role of a bus-bar voltage observer in DVR. When voltage sag is detected, the bypass switch is closed, and the required voltage is applied to the load.

### **V. DVR OPERATING MODES**

The DVR operates in three modes, which are presented below.

#### **A. Standby Mode**

The DVR is not supplying voltage to the load during this mode but due to transformer reactance it may inject some voltage for voltage drop compensation.

#### **B. Protection Mode**

Faults in the power grid cause large currents to flow, causing the DVR to be damaged. As a result, the DVR must be protected with protective devices such as breakers.

#### **C. Injection Mode**

When a voltage sag is sensed, the DVR comes into operation very quickly and the required voltage value is added to the load. In this way, the voltage sag is compensated.

### **VI. VOLTAGE INJECTION TECHNIQUES**

There are four voltage injection techniques employed in DVR topology:

#### **A. Pre-sag Technique**

This technique is superior since it adds the voltage difference between before and after the sag to the load, but it requires a big energy storage unit due to the uncontrolled injected active power.

#### **B. Phase Advance Technique**

The consumption of real power by DVR is reduced in this manner by reducing the power angle.

#### **C. Voltage Tolerance with Minimum Energy Technique**

We can keep the load voltage in the patience area with less voltage magnitude variation using this strategy.

#### **D. In-phase Voltage Injection Technique**

Due to in-phase connection of the added voltage with supply voltage, the non-variable value of load voltage is obtained despite varying phase angles of pre-sag and load voltage in this technique.

### **VII. CONCLUSIONS**

Voltage sag is a crucial problem that impacts a distribution system network, resulting in data loss, equipment damage, production loss, and cost increases. A Dynamic Voltage Restorer is proposed in this study for voltage sag compensation as a cost-effective solution that effectively protects critical loads from balanced or unbalanced voltage sag. This paper discusses the use of DVR in power systems for improving power quality and reducing harmonics, as well as other power quality issues such as voltage sag and voltage swell. The benefits of DVR devices in the power system are discussed, as well as the various DVR operating modes.

### **REFERENCES**

- [1] N.G. Hingorani, L. Gyugyi, 1999, -Understanding FACTS: Concepts and Technology of Flexible AC Transmission Systems, IEEE Press, New York.
- [2] Prabha Kundur, -Power system stability and control The Mc Graw Hill companies, Inc., New York, 1994

- [3] R. M. Mathur, R. K. Varma, -Thyristor-Based FACTS Controllers for Electrical Transmission Systems, Piscataway, NJ: IEEE Press, 2002
- [4] T. J. Miller, -Reactive power Control in Electric Systems, John Wiley & Sons, 1982
- [5] S. Meikandasivam, Rajesh Kumar Nema and Shailendra Kumar
- [6] S. Meikandasivam, Rajesh Kumar Nema, and Shailendra Kumar Jain, Performance of Installed TCSC Projects, Department of Electrical Engineering, Maulana Azad National Institute of Technology, Bhopal, INDIA 978 8/11, 2011 IEEE
- [7] Jain,-Behavioral study of TCSC device A MATLAB/Simulink
- [8] S. Sreejith, Sishaj P Simon, and M P Selvan, -Power flow analysis incorporating firing angle model Based TCSC, Proceedings of 5th International Conference on Industrial and Information Systems (ICIIS 2010), India 2010, Jul 29 -Aug 01, pp. 496-501
- [9] Vatsal J. Patel, C.B.Bhatt -Simulation and Analysis Real and Reactive Power Control with Series Type FACTS Controller IJETAE, Volume 2, Issue 3, March 2012, pp.7-11
- [10] Narayana Prasad Padhyay and M.A. Abdel Moamenl -Power flow control and solutions with multiple and Multi Type FACTS devices Electric Power Systems Research, Vol.74, 2005, pp. 341-351
- [11] Priyanka Kathal, Arti Bhandakkar -Power Flow Control in Power System using Thyristor controlled series capacitor IJSR INDIA ISSN: 2319- 7064, pp.72-83
- [12] C. A. Canizares and Z. T. Faur, -Analysis of SVC and TCSC Controllers in Voltage Collapse, IEEE ransactions on Power Systems, Vol. 14, No. 1, February 1999 pp.158 –165
- [13] Anita Kanwar, Rachit Saxena “Behavior of TCSC in transmission line using MATLAB/Simulationl ISSN (Online) 2321 – 2004 ISSN (Print) 2321 – 5526, pp.195-197
- [14] W. H. Litzemberger, R. K. Varma, and J. D. Flanagan, Eds.,“An Annotated Bibliography of High Voltage Direct Current Transmission and FACTS Devices”, 1996–1997, Published by the Electric Power Research Institute (EPRI) and the Bonneville Power Administration (BPA), Portland, OR, 1998
- [15] Toufan M, Annakkage UD, “Simulation of the unified power flow controller performance using PSCAD/EMTDC Electrical Power System”, Res 1998; 46:67-75
- [16] A. Chauhan and P. Thakur, Power Quality Issues and Their Impact on the Performance of Industrial Machines, Anchor Academic Publishing, 2016. IEEE
- [17] C. Udhayashankar, Princy Zachariah, Rani Thottungal, N. Nithyadevi, “SSSC Based Voltage Control and Power Oscillation Damping of Multi Area Power System”, ISSN 1450-216X Vol. 87 No 4 October, 2012, pp.479-49,
- [18] K. K. Sen, “SSSC Static Synchronous Series Compensator: Theory, Modeling and Applications”, IEEE Transactions on Power Delivery, Vol. 13, No. 1, January 1998, pp. 241 –246
- [19] S. H. E. A. Aleem, A. M. Saeed, A. M. Ibrahim, and E. E. A. El-Zahab, “Power Quality Improvement and Sag Voltage Correction by Dynamic Voltage Restorer,” International Review of Automatic Control (IREACO), vol. 7, no. 4, pp. 386-393–393, Jul. 2014, doi: 10.15866/ireaco.v7i4.2160.