

A Review on Spatial Modulation in Wireless Communication Systems

Anshul Sengar¹, Gaurav Morghare²

¹M Tech Scholar, Department of Electronics and Communication Engineering, O.I.S.T, Bhopal, India

Email: (anshulsengar26@gmail.com)

²Research Guide, Department of Electronics and Communication Engineering, O.I.S.T, Bhopal.

Abstract:

Spatial modulation (SM) is an modern and promising digital modulation technological expertise that strikes an captivating trade-off between spectral effectivity and energy effectivity with a handy graph philosophy. SM enjoys loads of benefits and suggests magnificent attainable to fulfill the requirements of future wi-fi communications. The key thought in the lower back of SM is to supply more files typically by the ON/OFF states of transmit antennas and at the same time as keep the implementation price by using way of reducing the extent of radio frequency chains. As a result, the SM questioning can have massive penalties on a number of features and can be utilized in exceptional signal domains such as frequency/time/code/angle vicinity or even at some point of greater than one domains. This survey affords a whole overview of the cutting-edge results and progresses in SM research. Specifically, the imperative principles, editions of machine design, and enhancements of SM are described in detail. Furthermore, the integration of the SM family with extraordinary promising techniques, functions to rising dialog systems, and extensions to new signal domains are moreover extensively studied.

Keywords — Spatial modulation (SM), generalized (G)SM, differential (D)SM, massiveMIMO, physical layer security, compressed-sensing, millimeter-wave communications, visible light communications etc.

I. INTRODUCTION

Driven through the skyrocketing increase of cellular units and the large applications of the Internet of matters (IoT), future wi-fi conversation structures have brought on the explosive demand and pressing want for ultra-high capacity, ultra-low latency, and large connectivity over the scarce wi-fi assets [1]–[4]. Specifically, an ever-increasing volume of cell records site visitors is anticipated to show up in the coming years, which can also weigh down the confined spectrum assets notably and make bigger the electricity consumption

dramatically [2]–[4]. Due to the unparalleled surge of cell statistics traffic, researchers have been prompted to enhance new transmission applied sciences for maximizing the possible throughput and minimizing the deployment cost. Among quite a number technologies, spatial modulation (SM) has been anticipated as one prospective digital modulation science to attain excessive spectral effectivity and electricity effectivity but revel in a easy graph principle. Note that the first works on SM date lower back to the starting of the 21-st century, when the preliminary SM was once first

explored in [5], [6]. Unfortunately, they did no longer acquire a lot interest in the early days. After 2008, lookup work on SM has begun to develop explosively and the systematic introduction of the SM thought has been stated in some tutorial/overview literature [7]–[10], which appeal to a lot of interest from researchers. By activating one transmit antenna to bring index information, SM reaps the spatial achieve with a single radio frequency (RF) chain and enjoys the following extra advantages [6], [7]:

- Higher strength effectivity [11], [12];
- Lower detection complexity with a smaller variety of acquire antennas and decrease complexity of RF circuits;
- Free of inter-channel interference;
- No want for inter-antenna synchronization;
- Compatibility with large multiple-input multiple-output (MIMO) [13].

In SM, greater data bits are usually conveyed thru the index of one lively transmit antenna, in addition to the records bits conveyed by using the traditional constellation symbol. Based on the antenna-switching mechanism, the lively antenna index modifications in accordance to the spatial data bits. In particular, solely one RF chain is required at the SM transmitter to prompt one out of more than one transmit antennas for a constellation image transmission, considerably saving the strength consumption in downlink communications, and dramatically decreasing the hardware fee at the person terminal in uplink communications. Moreover, due to freedom of the inter-channel interference, SM can be a higher candidate science than Vertical Bell Laboratories Layered Space-Time (VBLAST) for high-mobility wi-fi verbal exchange systems, the place the channel correlation is weakened whilst the inter-channel interference impact is aggravated [14]. Space shift keying (SSK) can be considered as a simplified variant of SM [15]–[21], which embeds the standard statistics into the index of one lively antenna solely besides involving any constellation symbol. Other editions of SM technological know-how usually consist of generalized (G)SM [22]–[24], quadrature SM (QSM) [6], differential (D)SM [7]–[9], obtain (R)SM [3], and generalized (G)SSK [4]. Generally

speaking, SM refers to a new modulation household of verbal exchange structures that conveys extra statistics commonly via the activation states of transmit antennas. By deciding on distinctive activation Driven via the skyrocketing expand of mobile devices and the giant functions of the Internet of things (IoT), future Wi-Fi dialog constructions have introduced on the explosive demand and urgent prefer for ultra-high capacity, ultra-low latency, and giant connectivity over the scarce wi-fi property [1]–[4]. Specifically, an ever-increasing volume of phone archives web site traffic is predicted to exhibit up in the coming years, which can additionally weigh down the constrained spectrum belongings distinctly and make larger the electrical energy consumption dramatically [2]–[4]. Due to the unparalleled surge of cellphone facts traffic, researchers have been caused to beautify new transmission utilized sciences for maximizing the feasible throughput and minimizing the deployment cost. Among pretty a quantity technologies, spatial modulation (SM) has been predicted as one prospective digital modulation science to acquire immoderate spectral effectivity and electrical energy effectivity however revel in a effortless format principle. Note that the first works on SM date decrease returned to the beginning of the 21-st century, when the preliminary SM was once as soon as first explored in [5], [6]. Unfortunately, they did no longer gather a lot pastime in the early days. After 2008, look up work on SM has begun to increase explosively and the systematic introduction of the SM notion has been cited in some tutorial/overview literature [7]–[10], which attraction to a lot of activity from researchers. By activating one transmit antenna to deliver index information, SM reaps the spatial attain with a single radio frequency (RF) chain and enjoys the following more blessings [6], [7]:

- Greater electricity effectivity [11], [12];
- Decrease detection complexity with a smaller range of gather antennas and reduce complexity of RF circuits;
- Free of inter-channel interference;
- No favor for inter-antenna synchronization;
- Compatibility with giant multiple-input multiple-output (MIMO) [13].

In SM, increased facts bits are typically conveyed through the index of one energetic transmit antenna, in addition to the data bits conveyed via the use of the standard constellation symbol. Based on the antenna-switching mechanism, the active antenna index adjustments in accordance to the spatial facts bits. In particular, totally one RF chain is required at the SM transmitter to instant one out of extra than one transmit antennas for a constellation picture transmission, appreciably saving the electricity consumption in downlink communications, and dramatically reducing the hardware price at the man or woman terminal in uplink communications. Moreover, due to freedom of the inter-channel interference, SM can be a greater candidate science than Vertical Bell Laboratories Layered Space- Time (VBLAST) for high-mobility wi-fi verbal change systems, the area the channel correlation is weakened at the same time as the inter-channel interference have an effect on is aggravated [14]. Space shift keying (SSK) can be viewed as a simplified variant of SM [15]–[21], which embeds the fashionable data into the index of one active antenna completely except involving any constellation symbol. Other versions of SM technological expertise generally consist of generalized (G)SM [22]–[24], quadrature SM (QSM) [6], differential (D)SM [7]–[9], gain (R)SM [3], and generalized (G)SSK [4]. Generally speaking, SM refers to a new modulation family of verbal change constructions that conveys more records normally by using the activation states of transmit antennas. By finding out on extraordinary activation patterns at the transmitter, a quantity SM persons provide a flexible diagram to meet special specific requirements and trade-offs amongst the spectral efficiency, energy efficiency, deployment cost, and machine performance. For information recovery, the receivers of SM have to execute two most important obligations [5]:

- Detecting the indices/states of energetic antennas;
- Demodulating the constellation symbols embedded on the active antennas/states (if applicable).

II. RELATED WORK

However, it is no longer trivial to efficiently recognize every spatial and constellation archives effectually at the same time as maintaining low complexity for SM contributors below distinct channel stipulations [25], [6]. On the one-of-a-kind hand, link-adaptive SM, which relies upon on the remarks from the receiver to alter its transmission pattern (e.g., modulation order, transmit electricity and antenna selection), was once as soon as incredibly investigated to gather greater desktop universal overall performance and channel utilization [7]. Please be conscious that the detection ordinary overall performance of easy SM surprisingly relies upon on the distinctness of the channel signatures/fingerprints associated with unique transmit antennas. As a result, simple SM enjoys the technical mission to feature in rich scattering propagation and stationary [1] environments. With in addition leverage of obtain preprocessing techniques, such as orthogonal pulse shaping [2] and trellis coded modulation (TCM) [3], [4], the bother of lack of channel distinctness can be well addressed in SM systems. Furthermore, as easy SM makes use of the region region to supply index statistics with the resource of one energetic antenna, no transmit-diversity collect is furnished via the usage of easy SM to battle channel fading effects. To overcome the lack of transmit-diversity inherent in plain SM, transmit- vary increased SM the utilization of space-time block coding (STBC) is moreover a promising direction to beautify the error universal overall performance [5]–[9].

Due to its many promising advantages, SM serves as an acceptable energy-efficient modulation technological information with flexi- bility of working at the same time with others in rising communi- cation systems. Thanks to the sparsity inherent in SM signals, compressed-sensing (CS) thought is a positive machine for low- complexity signal reconstruction even when the range of available measurements is lots smaller than the signal dimen- sion (i.e., the large range of collect antennas is heaps plenty much less than that of transmit antennas in underdetermined systems), in unique in the case of large-scale MIMO [3]. On the one-of-a-kind hand, due to the significantly lowered

wavelength in the millimeter-wave (mmWave) frequency band, mmWave buildings can be geared up with a huge range of antennas at the transceiver in a relatively compact manner for the implementation of large-scale MIMO [4]. As a result, the SM family emerges as a promising low priced and high-efficiency candidate for large-scale MIMO with a large variety of transmit antennas while a complete lot smaller extent of RF chains are required for antenna activation. More recently, noticing the great potentials of non-orthogonal multiple access (NOMA) in supporting massive connectivity and low transmission latency, NOMA aided SM emerges as an captivating and novel science for multi-user communications, which achieves immoderate spectral effectivity and energy effectivity even as holding low-complexity transceiver design [5]–[7]. As a result, NOMA aided SM science strikes an appealing trade-off amongst spectral efficiency, electrical energy efficiency, deployment cost, and interference mitigation [8]. Simultaneous wireless information and power transfer (SWIPT) is any different rising vital technology, which interests at turning in wi-fi statistics and electrical energy concurrently. SM finds its one-of-a-kind suit to SWIPT-enabled wi-fi constructions when you think about that it has the potential to leverage the inactive antennas for electrical energy harvesting without incurring any loss of the spectral efficiency. Moreover, due to the broadcast nature of wi-fi communications, the security of SM transmission is an indispensable problem in workout [9]. Interestingly, every bodily layer protection (PLS) and SM specially count number on the randomness and discrimination homes of the wi-fi interface, which can be exploited to reap private records alternate amongst decent nodes while impairing the achievable eavesdropper at the equal time. Specifically, SM employs a rapidly antenna-switching mechanism to reap the random selection of transmit antennas in accordance to the spatial data bits and the reputable channel state information (CSI), which can incur speedy time-varying environments to confuse the eavesdropper and degrade its decoding performance. In specific words, SM suggests a terrific achievable now not totally in its accelerated electricity efficiency, then again

moreover in the feasibility of impenetrable transmission. Furthermore, thinking about that considered slight communications (VLC) enjoys immoderate safety and helps the speedy switching in light-emitting diodes (LEDs), SM science can additionally be except situation built-in into VLC, which affords the flexibility to manipulate the luminance of the LED array and the verbal change throughput[2].

Although originated in the location domain, the thinking of SM is now no longer distinct to the residence domain, then again can be generalized and utilized to exclusive signal domains such as frequency/time/code/angle vicinity or even at some stage in extra than one domains. As a consequence, significant interest and hobby have been paid in contemporary years to totally beef up a quantity sorts of the SM wondering in severa wi-fi dialog features [3], [6]. The use of the ON/OFF keying mechanism to embed index records has been commonly talking utilized to entities in single domains such as spatial location (e.g., antenna, RF mirror, and LED), frequency vicinity (e.g., subcarrier), time region (e.g., time slot), code place (e.g., spreading code and modulation type), and standpoint region (e.g., mindset of arrival (AoA) and polarization state). To in a similar way adorn the system typical overall performance and trip a higher flexible design, multi-dimension entities are moreover developed, which consist of increased than one dimension for performing the ON/OFF keying mechanism.

III. SPATIAL MODULATION

In this section, we first introduce the simple precept of SM and then talk about some variations of SM, inclusive of (G)SM and (D)SM. We think about the implementations of SM in a MIMO gadget with N_T transmit and N_R obtain antennas.

A. Single-RF SM

At the establishing of this century, SM has emerged as a novel MIMO science that works with a single RF chain and exploits the energetic antenna index to bring extra records primarily based on the antenna-switching mechanism [6], [7]. As a result, the facts of SM is now not solely explicitly

transmitted as one phase-shift keying (PSK)/quadrature amplitude modulation (QAM) symbol, however additionally implicitly transmitted with the aid of deciding on the index of one energetic antenna for every channel use. Given the quantity of transmit antennas N_T and the modulation order of the sign constellation M , the spectral effectivity of SM is

$$SSM = \log_2 N_T + \log_2 M \text{ [bpcu]} \quad (1)$$

where [bpcu] stands for bits per channel use. Specifically, the first phase of $\log_2 N_T$ bits determines the index of the lively antenna j and the 2d section of $\log_2 M$ bits is used to modulate the constellation image s .

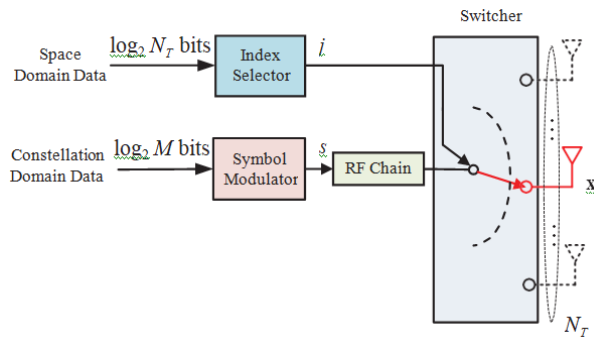

Figure 1. Transmitter diagram for the SM system.

B. Generalized (G)SM

Although the single-RF SM enjoys excessive power effectivity with one lively antenna, one primary downside is that spectral effectivity suffers from a sluggish logarithmic boom with an growing range of transmit antennas. Hence, the constraint of a single energetic antenna is blissful in (G)SM to supply extra spatial statistics via permitting extra than one antennas to be concurrently activated to transmit the equal PSK/QAM image [22], [23]. Since the identical PSK/QAM image is transmitted from all lively antennas, this (G)SM scheme requires solely one RF chain and is additionally free of inter-channel interference and there is no want for inter-antenna synchronization. For every channel use, K out of N_T ($K < N_T$) transmit antennas are chosen to raise the identical constellation image whilst the last $N_T - K$ antennas are inactivated.

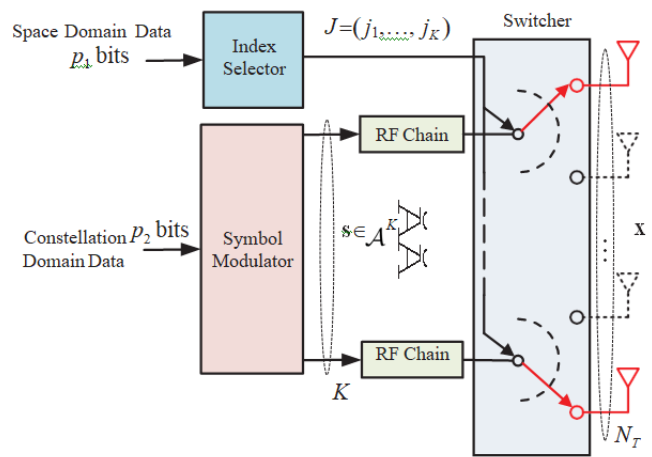

Figure 2. Transmitter diagram for the (G)SM system.

C. Differential (D)SM

Since the SM transmitter embeds the spatial records in the energetic antenna implicitly, the SM receiver has to become aware of such spatial records by way of distinguishing distinctive channel fading states related with distinct transmit antennas, which requires the CSI for coherent detection. However, the CSI requirement at the receiver will increase the deployment price due to the pilot overhead and channel estimation complexity. Alternatively, differential encoding of the SM symbols, which dispenses with any CSI at the transceiver whilst inheriting the benefits of SM, emerges as an beautiful solution with low deployment cost. A differentially encoded space-time shift keying (STSK) modulation scheme is introduced in [109] as the primitive concept of (D)SM, which employs the Cayley unitary seriously change and conveys data by the activation country.

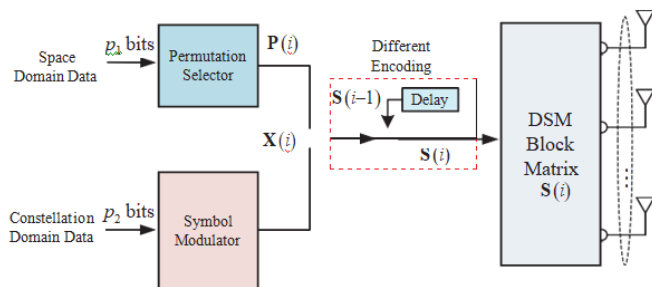

Figure 5. Transmitter diagram for the (D)SM system.

Receive (R)SM

As a reciprocal scheme of SM technology, RSM, a.k.a. precoding aided SM (PSM), has additionally obtained a lot of lookup hobby due to its simplified acquire structure. Specifically, through making use of the idea of SM at the receiver-side, RSM makes use of the indices of acquire antennas to deliver spatial records in addition to traditional constellation statistics of P- SK/QAM symbol. With the useful resource of transmitter precoding, RSM advantages from each excessive beamforming achieve and low complexity diagram at the receiver side, which is exceptionally preferred for the downlink MIMO transmission.

With the best CSI handy at the transmitter, the preliminary RSM is explored in the place each zero-forcing (ZF) and minimal mean-squared error (MMSE) pre-coding schemes are considered. Two precoding schemes for RSM beneath imperfect CSI at the transmitter-side are then developed in [3]. Moreover, the idea of RSM is additionally generalized via activating greater than one antennas at the receiver-side [in which error overall performance and the low-complexity detectors are investigated. In [4], a non-linear RSM scheme is developed with the leverage of vector perturbation, which conveys implicit statistics by using the activation sample at the receiver-side. The authors of [5] increase a new RSM scheme to reap each transmit and acquire diversity, the place quite a few related detection algorithms are added to meet distinctive necessities in phrases of complexity and reliability. To limit the enormous channel estimation overheads required at the transmitter, a two-stage RSM primarily based on partial CSI is proposed in [6] for correlated channels. Moreover, to overcome the overall performance degradation due to the channel correlation, an orthogonality shape is designed for generalized RSM [7]. Based on the ML criterion, both

coherent and incoherent detection schemes are studied in [8], which are then simplified to the single-tap detection problem.

TABLE I CLASSIFICATION OF REPRESENTATIVE FORMS OF SM.

Type	Entity		Representative Schemes	Main Achievements
Single-Dimension Entity	Space Domain	Antenna	SM [6], SSK [1], (G)SM [2], (G)SSK [4], QSM [6]	Higher energy efficiency & lower deployment cost
		LED	OSM [1]	Flexibility to control illumination & Communications
		RF Mirror	RA-SSK [2], CM [3]	Better system performance & lower antenna cost
	Frequency Domain	Subcarriers	SIM-OFDM [240], OFDM-IM [98], OFDM-I/Q-IM[5], GFDM-IM [6]	Higher spectral efficiency & higher energy efficiency
		Subcarriers	CI-OFDM-IM [7], MIMO- OFDM-IM [8]–[11]	Higher reliability & higher energy efficiency
	Time Domain	Time slot	SC-IM [12]	Higher transmission efficiency for broadband systems
	Code Domain	Spreading Code	CIM-SS [249], GCIM-SS [14], IM-OFDM-SS [15]	Higher spectral efficiency & lower energy consumption
Modulation Type		ESM[16], DM-OFDM [17], MM-OFDM-IM [18]	Higher spectral efficiency	
Angle Domain	Polarization State	PolarSK [19], 3-D Mod [20]	Higher spectral efficiency & lower hardware cost	
	AoA	BACM [21]	Higher spectral efficiency	
Multi-Dimension Entity	Space-Time		STSK [109]	Flexible tradeoff between diversity & multiplexing gain
	Space-Frequency		GSFIM [22]	Better system performance
	Space-Time-Frequency		STFSK [23], GSTFIM [24]	Higher spectral efficiency

IV. CONCLUSION

SM is a promising digital modulation technological know-how to fulfill the necessities of rising wi-fi structures due to its possible of attaining excessive strength efficiency, low deployment cost, free of interchannel interference, at ease inter-antenna synchronization requirements, and compatibility with huge MIMO systems. As proven in this survey, relying on the activation states of transmit antennas to carry extra in- formation, SM can obtain an

fascinating compromise between spectral effectivity and electricity effectivity with easy diagram philosophy, which has been tested via enormous studies. We have first discussed the fundamental principles, variants, and enhancements of SM, and then proven the wide potentialities of the SM thinking in quite a number implementations, such as integration with different promising techniques, functions to rising conversation systems, and extensions to new domains. We hope that this survey and the lookup outcomes in this exceptional trouble will be useful to the readers to attain a higher appreciation and clearer photo on the blessings and possibilities of the SM household as properly as its wide-range applications.

REFERENCES

- [1] R. Mesleh, H. Elgala, and H. Haas, "Optical spatial modulation," *IEEE/OSA J. Opt. Commun. Netw.*, vol. 3, no. 3, pp. 234–244, Mar. 2011.
- [2] Z. Bouida, H. El-Sallabi, A. Ghayeb, and K. A. Qaraqe, "Reconfigurable antenna-based space-shift keying (SSK) for MIMO Rician channels," *IEEE Trans. Wireless Commun.*, vol. 15, no. 1, pp. 446–457, Jan. 2016.
- [3] E. Basar and I. Altunbas, "Space-time channel modulation," *IEEE Trans. Veh. Technol.*, vol. 66, no. 8, pp. 7609–7614, Aug. 2017.
- [4] R. Abu-alhiga and H. Haas, "Subcarrier-index modulation OFDM," in *Proc. IEEE Int. Symp. Personal, Indoor, Mobile Radio Commun. (PIMRC)*, Tokyo, Japan, Sept. 2009, pp. 177–181.
- [5] B. Zheng, F. Chen, M. Wen, F. Ji, H. Yu, and Y. Liu, "Low-complexity ML detector and performance analysis for OFDM with in-phase/quadrature index modulation," *IEEE Commun. Lett.*, vol. 19, no. 11, pp. 1893–1896, Nov. 2015.
- [6] E. Ozturk, E. Basar, and H. A. Cirpan, "Generalized frequency division multiplexing with index modulation," in *Proc. IEEE Globecom Workshops (GC Wkshps)*, Washington, DC, USA, Dec. 2016, pp. 1–6.
- [7] E. Baar, "OFDM with index modulation using coordinate interleaving," *IEEE Wireless Commun. Lett.*, vol. 4, no. 4, pp. 381–384, Aug. 2015.
- [8] "Multiple-input multiple-output OFDM with index modulation," *IEEE Signal Process. Lett.*, vol. 22, no. 12, pp. 2259–2263, Dec. 2015.
- [9] E. Basar, "On multiple-input multiple-output OFDM with index modulation for next generation wireless networks," *IEEE Trans. Signal Process.*, vol. 64, no. 15, pp. 3868–3878, Aug. 2016.
- [10] B. Zheng, M. Wen, E. Basar, and F. Chen, "Multiple-input multiple-output OFDM with index modulation: Low-complexity detector design," *IEEE Trans. Signal Process.*, vol. 65, no. 11, pp. 2758–2772, Jun. 2017.
- [11] "Low-complexity near-optimal detector for multiple-input multiple-output OFDM with index modulation," in *Proc. IEEE Int. Conf. Commun. (ICC)*, Paris, France, May 2017, pp. 1–6.
- [12] M. Nakao, T. Ishihara, and S. Sugiura, "Single-carrier frequency-domain equalization with index modulation," *IEEE Commun. Lett.*, vol. 21, no. 2, pp. 298–301, Feb. 2017.
- [13] G. Kaddoum, M. F. A. Ahmed, and Y. Nijasure, "Code index modulation: A high data rate and energy efficient communication system," *IEEE Commun. Lett.*, vol. 19, no. 2, pp. 175–178, Feb. 2015.
- [14] G. Kaddoum, Y. Nijasure, and H. Tran, "Generalized code index modulation technique for high-data-rate communication systems," *IEEE Trans. Veh. Technol.*, vol. 65, no. 9, pp. 7000–7009, Sept. 2016.
- [15] Q. Li, M. Wen, E. Basar, and F. Chen, "Index modulated OFDM spread spectrum," *IEEE Trans. Wireless Commun.*, vol. 17, no. 4, pp. 2360–2374, Apr. 2018.
- [16] C. Cheng, H. Sari, S. Sezginer, and Y. T. Su, "Enhanced spatial modulation with multiple signal constellations," *IEEE Trans. Commun.*, vol. 63, no. 6, pp. 2237–2248, Jun. 2015.
- [17] T. Mao, Z. Wang, Q. Wang, S. Chen, and L. Hanzo, "Dual-mode index modulation aided OFDM," *IEEE Access*, vol. 5, pp. 50–60, 2017.
- [18] M. Wen, E. Basar, Q. Li, B. Zheng, and M. Zhang, "Multiple-mode orthogonal frequency division multiplexing with index modulation," *IEEE Trans. Commun.*, vol. 65, no. 9, pp. 3892–3906, Sept. 2017.
- [19] J. Zhang, Y. Wang, J. Zhang, and L. Ding, "Polarization shift keying (PolarSK): System scheme and performance analysis," *IEEE Trans. Veh. Technol.*, vol. 66, no. 11, pp. 10 139–10 155, Nov. 2017.
- [20] P. Henarejos and A. I. Prez-Neira, "3-d polarized modulation: System analysis and performance," *IEEE Trans. Commun.*, vol. 66, no. 11, pp. 5305–5316, Nov. 2018.
- [21] J. Hoseyni and J. Ilow, "Beam angle channel modulation," in *Proc. IEEE Veh. Technol. Conf. (VTC Fall)*, Toronto, ON, Canada, Sept. 2017, pp. 1–6.
- [22] T. Datta, H. S. Eshwaraiyah, and A. Chockalingam, "Generalized space-time-frequency index modulation," *IEEE Trans. Veh. Technol.*, vol. 65, no. 7, pp. 4911–4924, Jul. 2016.
- [23] H. A. Ngo, C. Xu, S. Sugiura, and L. Hanzo, "Space-time-frequency shift keying for dispersive channels," *IEEE Signal Process. Lett.*, vol. 18, no. 3, pp. 177–180, Mar. 2011.
- [24] M. I. Kadir, "Generalized space-time-frequency index modulation," *IEEE Commun. Lett.*, to be published, 2018.
- [25] O. P. Mishra and G. Morghare, "An Efficient approach Network Selection and Fast Delivery Handover Route 5G LTE Network," 2019 3rd International Conference on Trends in Electronics and Informatics (ICOEI), 2019, pp. 857–862, doi: 10.1109/ICOEI.2019.8862791.